

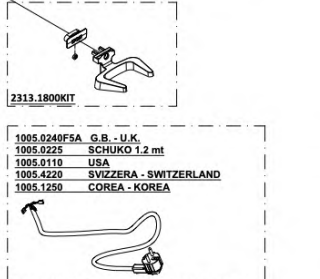

# MIGNON MANUALE

29/09/2021

110V/60Hz  
 220V/60Hz  
 220-230V/50Hz  
 230-240V/50Hz

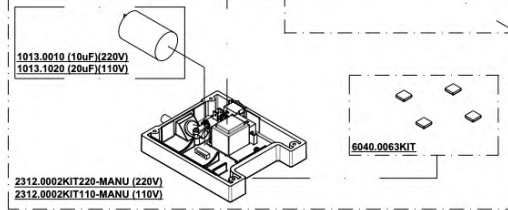
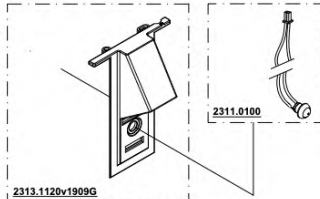
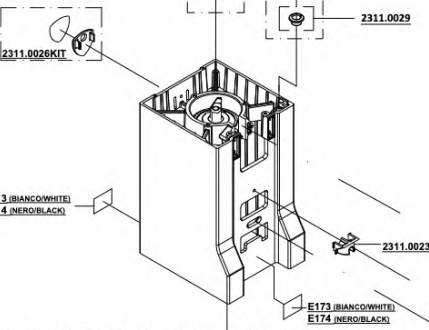
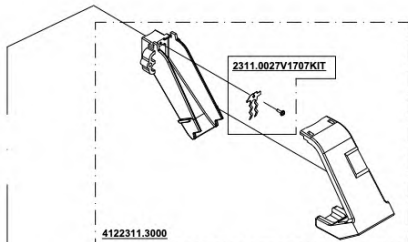
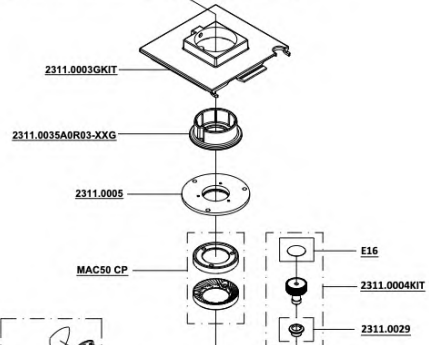
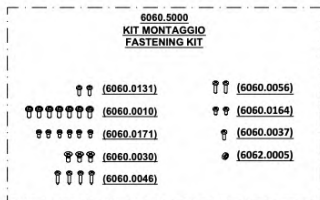
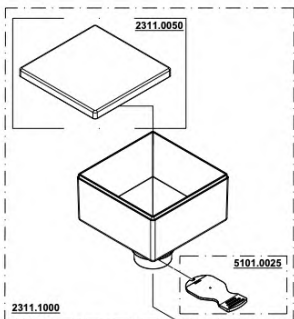

1005.0240FSA G.B. - U.K.  
 1005.0225 SCHUKO 1.2 mt  
 1005.0110 USA  
 1005.4220 SVIZZERA - SWITZERLAND  
 1005.1250 COREA - KOREA

N.B. : DOVE INDICATO CON "XXX" SI RICHIEDE DI SPECIFICARE IL COLORE  
 PLEASE NOTE : WHERE "XXX" IS INDICATED YOU HAVE TO SPECIFY THE COLOUR